

**Dynamic Fire Damper • 1½ Hr. Rated • Horizontal and Vertical Mount • Non-Motorized • Galvanized Steel**

## STANDARD CONSTRUCTION

- FRAME:** 5½" x 7⁄8" x 16 GA. galvanized steel hat channel.
- BLADES:** 16 GA. galvanized steel, 6" nominal width, parallel action.
- AXLES:** Square, plated solid steel stub.
- BEARINGS:** Oil impregnated bronze.
- LINKAGE:** Plated steel angle and crank plates with stainless steel pivots in-jamb type.
- STOPS:** 18 GA. galvanized steel at head and sill.
- JAMB SEALS:** Stainless Steel.
- FINISH:** Mill.
- ACTUATOR:** Non-motorized spring closure mechanism with 165°F fusible link.

**UNDERWRITERS LABORATORIES INC.®**

CLASSIFIED DYNAMIC FIRE DAMPER

FIRE RESISTANCE RATING 1½ HR

**FILE # R16591**

This fire damper meets the construction and performance requirements of

- Underwriters Laboratories Inc. Standards 555
- National Fire Protection Association Standards 80, 90A, 101
- ICC's International Building Code
  
- Underwriters Laboratories Inc. Approved for dual direction airflow and dynamic conditions.
- Underwriters Laboratories Inc. Classified for use in fire resistive ratings of less than 3 hours.

## OPTIONS

- Type 304 Stainless Steel Construction (Sleeve and in-airstream parts only)
- Sleeve of various depths and gauges
- Round or oval transitions
- 212°F fusible link
- Dual Position Indication Package (see Notes)

## NOTES

1. Nominal deductions will be made to the opening size given.
2. Optional auxiliary blade position indication switches are rated at 11A, ½HP, 125VAC. These snap action switches are intended to make or break a circuit and will not provide variable or proportional resistance.
3. See SI-SSFD for information regarding Stainless Steel Fire Dampers.

## DAMPER SIZES

		2000 fpm, 4 in.wg				4000 fpm, 4 in.wg
Orientation	Hor & Vert	Horizontal (floor)		Vertical (wall)		Hor & Vert
Panels	Min Panel	Max Single Panel	Max Assy Panel	Max Single Panel	Max Assy Panel	Max Single Panel
Rectangular	4"W x 4"H (8"W x 8"H frame)	36"W x 48"H	72"W x 48"H	36"W x 48"H	72"W x 60"H 126"W x 48"H	36"W x 48"H
Round	6" dia. (8"W x 8"H frame)	34" dia.	46" dia.	34" dia.	58" dia.	34" dia.
Oval	6"W x 6"H (8"W x 8"H frame)	34"W x 46"H	70"W x 46"H	34"W x 46"H	70"W x 58"H 124"W x 46"H	34"W x 46"H

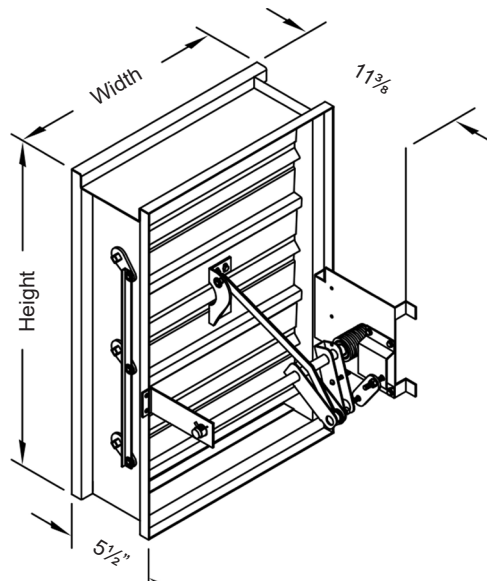

In the interest of product development, Louvers & Dampers reserves the right to make changes without notice.

[www.louvers-dampers.com](http://www.louvers-dampers.com)

450 Riverside Drive • Wyalusing PA, 18853 • Phone 570-746-1888 • Fax 570-746-9286



